

advantage

2 piston blank lug

R-type caliper

PRODUCT REF

CLR280/11-35LL

CLR280/11-35RL

CLR280/11-35LT

CLR280/11-35RT

KEY FEATURES AND BENEFITS

- **Blank lug**
Can be machined to suit a wide variety of applications
- **Made from aerospace grade aluminium alloy**
High strength to weight ratio
- **Hard anodised finish**
High wear and corrosion resistance
- **Uses popular R-type pad shape**
Wide range of friction materials available
- **Quick release pad retaining clip**
- **High temperature EPDM seal material**
Optimum piston control

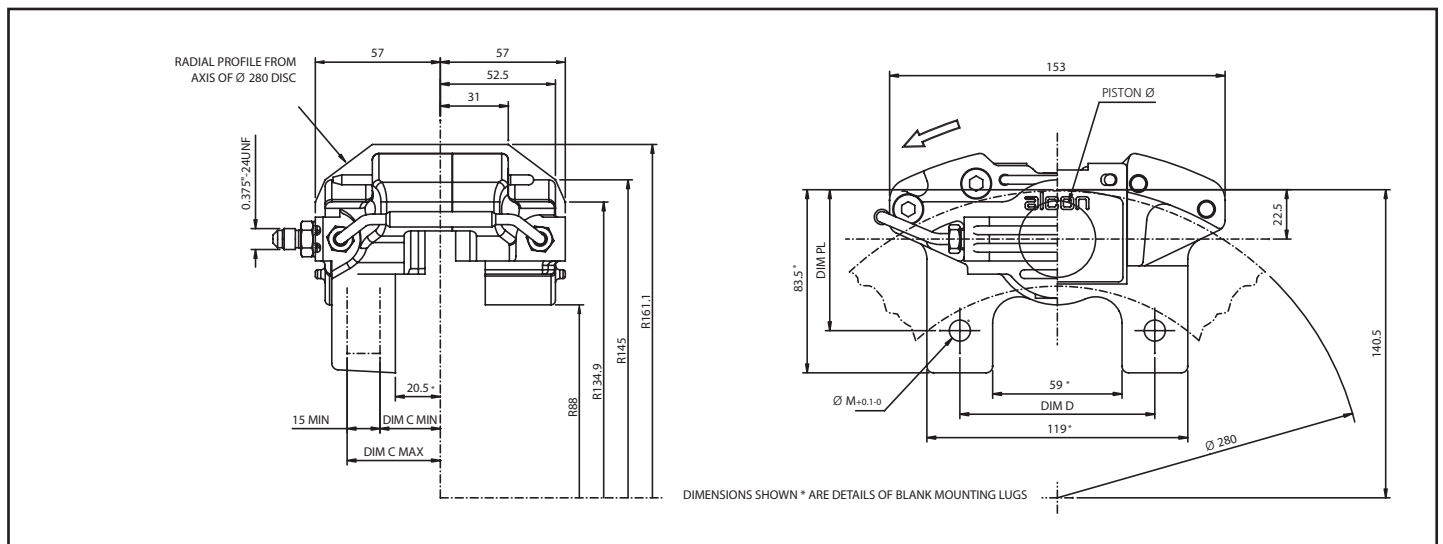
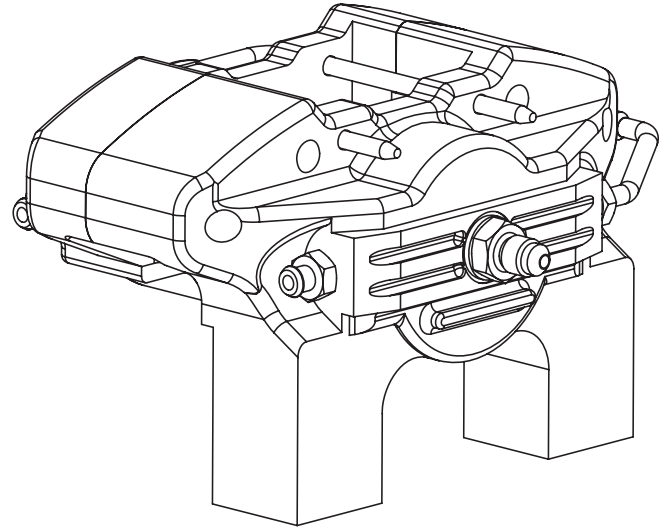

SPECIFICATION

piston diameter	34.9
disc diameter	250-280
disc thickness	9.6-11.1
caliper weight	1.30 kg
pad area	49.8 cm ²
pad thickness	14
seal kit reference	CSK35E900

MOUNTING DETAILS

DIM C min	20.5
DIM C max	46.0
DIM D min	86.0
DIM D max	90.0
diameter M min	9.6
diameter M max	12.2
DIM PL min	47.0
DIM PL max	69.0

PAD REFERENCES

Alcon	RC3451XSP
Carbone Lorraine	5002
Ferodo	FCP809
Hawk	HB118
Mintex	MGB533
Pagid	U3102
SBS	3060