

advantage

4 piston blank lug

H-type caliper

PRODUCT REF

CLH304/25-38/41LL

CLH304/25-38/41RL

CLH304/25-38/41LT

CLH304/25-38/41RT

KEY FEATURES AND BENEFITS

- **Blank lug**
Can be machined to suit a wide variety of applications
- **Made from aerospace grade aluminium alloy**
High strength to weight ratio
- **Differential piston diameters**
Minimises pad taper wear
- **Uses popular H-type pad shape**
Wide range of friction materials available
- **Pad retaining sleeve**
High rigidity with straightforward pad changes

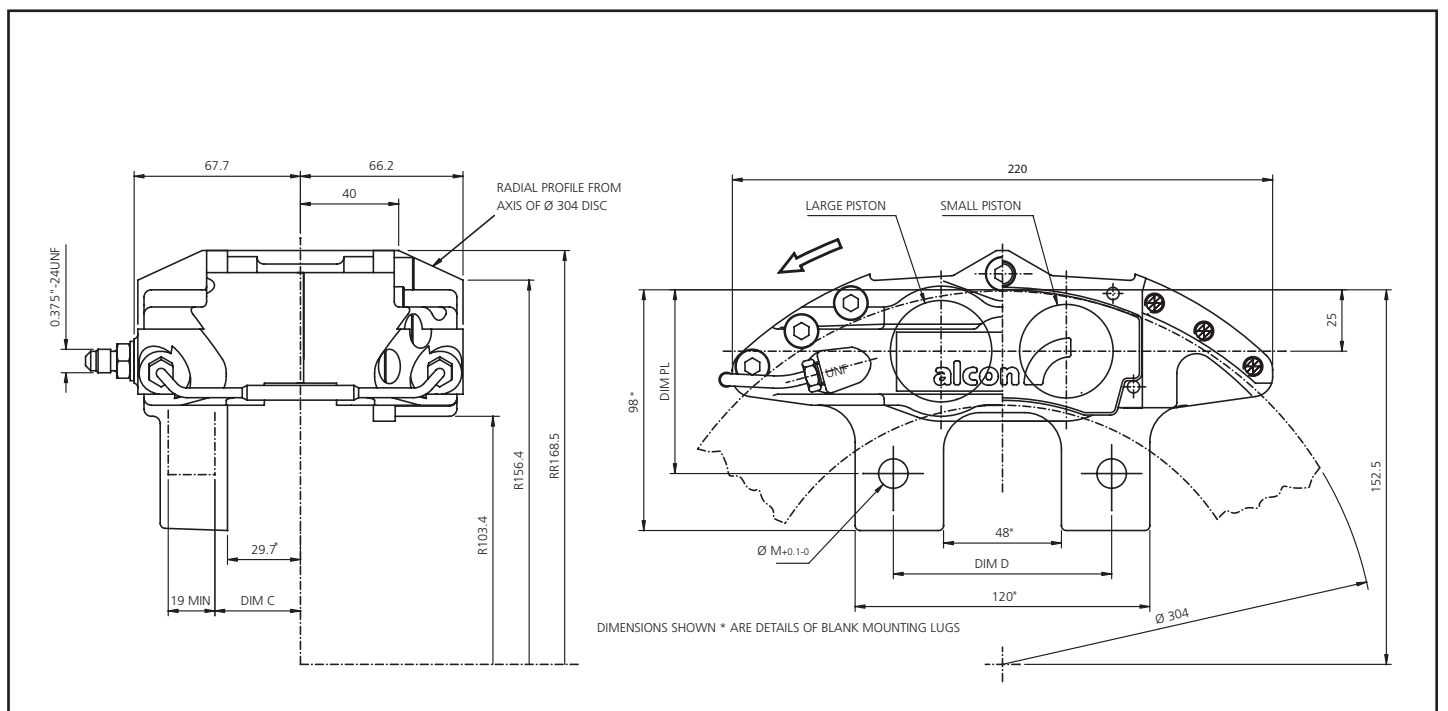
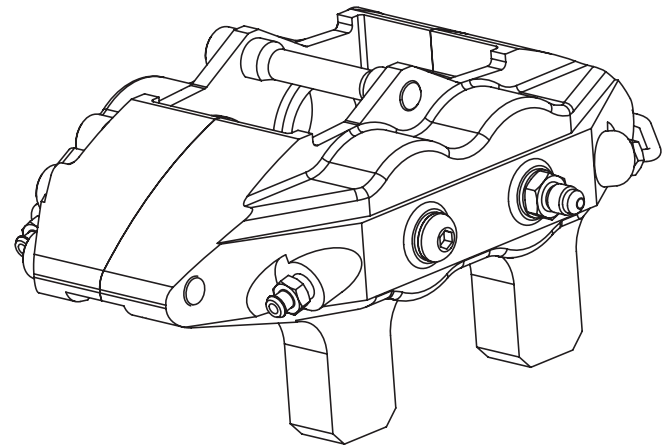

SPECIFICATION	
piston diameter	38.1 / 41.3
disc diameter	250-304
disc thickness	22-25.4
caliper weight	2.2 kg
pad area	84 / 89 cm ²
pad thickness	16
seal kit reference	CSK3841E900

MOUNTING DETAILS	
DIM C min	29.7
DIM C max	39.7
DIM D min	76.0
DIM D max	90.0
diameter M min	9.6
diameter M max	12.2
DIM PL min	55.0
DIM PL max	85.0

PAD SHAPES	
Alcon	4463
Carbone Lorraine	5007W43 / 5003W48
Ferodo	FRP219 / FRP201
Hawk	HB107
Mintex	MDB1200 / MDB1864
Pagid	U1265
SBS	3001